



**1411 Size SAW Filter for DCS (GSM1800)  
Low Insertion Loss Version  
SPEC SHEET**

*Preliminary*

Part No. WF892D1842FD

Document No. CE-892D-01

Issue Date Sep, 28, 2005

**NIHON DEMPA KOGYO CO., LTD  
KSP TECHNICAL CENTER**

KSP-D437, 3-2-1, Sakado, Takatsu-Ku, Kawasaki 213-0012, Japan  
Tel: +81-44-814-3471, Fax: +81-44-814-3478

### 1. Scope

This document contains specification and data sheet which applies to 1411 size SAW filter for DCS(GSM1800)-band.

### 2. Part Number

Part Number	Center Frequency	Part Size	Shipment
WF892D1842FD	1842.5MHz	1.4mmx1.1mmx0.6mm	Tape and reel

### 3. Dimensions

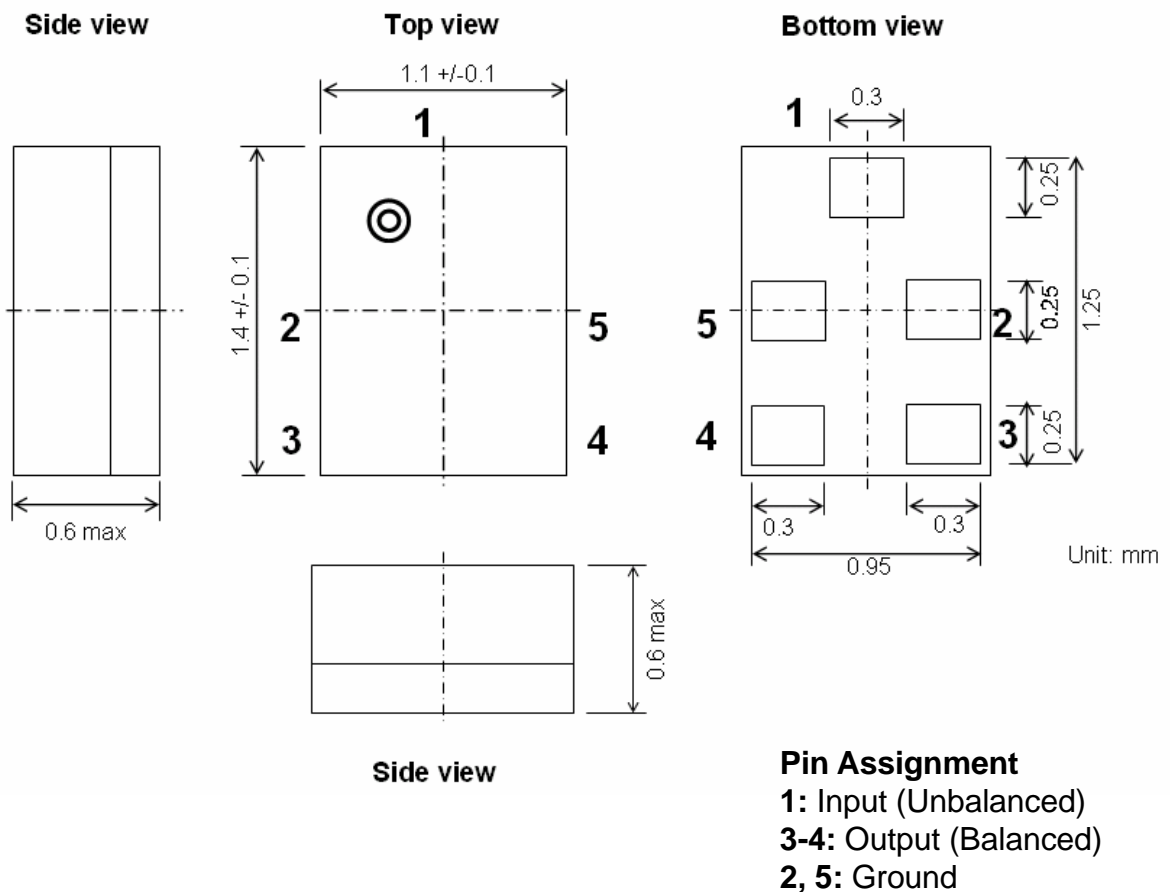

#### 4. Maximum Ratings

4-1 Operating temperature range (Ta): -20°C to 85°C

4-2 Storage temperature range: -40°C to 85°C

4-3 Input RF power: 12dBm max. (GSM signal peak power, 4:8 duty cycle)

#### 5. Test Circuit

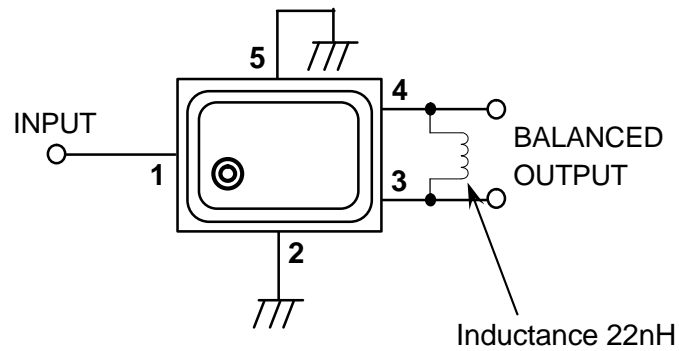

## 6. Electrical Characteristics

### 6-1 Specification

1) at 25+/- 2 °C (room temp.)

Item	Min.	Typ.	Max.	Unit	
Center Frequency	-	1842.5	-	MHz	
Insertion Loss	1805 ... 1880 MHz	-	1.6	1.9	dB
Amplitude Ripple	1805 ... 1880 MHz	-	0.5	0.9	dB
Input VSWR	1805 ... 1880 MHz	-	1.9	2.2	-
Output VSWR	1805 ... 1880 MHz	-	1.9	2.2	-
Absolute Attenuation					
	100 ... 1300 MHz	35	52		dB
	1300 ... 1705 MHz	20	30	-	dB
	1705 ... 1785 MHz	15	20	-	dB
	1920 ... 1980 MHz	15	20	-	dB
	1980 ... 3000 MHz	19	21	-	dB
	3000 ... 4000 MHz	40	53		dB
	4000 ... 5000 MHz	40	54	-	dB
	5000 ... 6000 MHz	30	40	-	dB
Amplitude Balance	-1.1	-0.5/+0.5	1.1	dB	
Phase Balance	-15	-10/+10	15	deg.	
Input Impedance (unbalanced)	50			ohm	
Output Impedance (balanced)	150ohm // 22nH			ohm	

## 2) at operating temp. from -20 to 85°C

Item	Min.	Typ.	Max.	Unit	
Center Frequency	-	1842.5	-	MHz	
Insertion Loss	1805 ... 1880 MHz	-	1.6	2.5	dB
Amplitude Ripple	1805 ... 1880 MHz	-	0.5	1.5	dB
Input VSWR	1805 ... 1880 MHz	-	1.9	2.3	-
Output VSWR	1805 ... 1880 MHz	-	1.9	2.3	-
Absolute Attenuation					
	100 ... 1300 MHz	35	52		dB
	1300 ... 1705 MHz	20	30	-	dB
	1705 ... 1785 MHz	12	20	-	dB
	1920 ... 1980 MHz	12	20	-	dB
	1980 ... 3000 MHz	18	21	-	dB
	3000 ... 4000 MHz	40	53		dB
	4000 ... 5000 MHz	40	54	-	dB
	5000 ... 6000 MHz	30	40	-	dB
Amplitude Balance	-1.5	-0.5/+0.5	1.5		dB
Phase Balance	-15	-10/+10	15		deg.
Input Impedance (unbalanced)	50				ohm
Output Impedance (balanced)	150ohm // 22nH				ohm

6-2 Measured characteristics

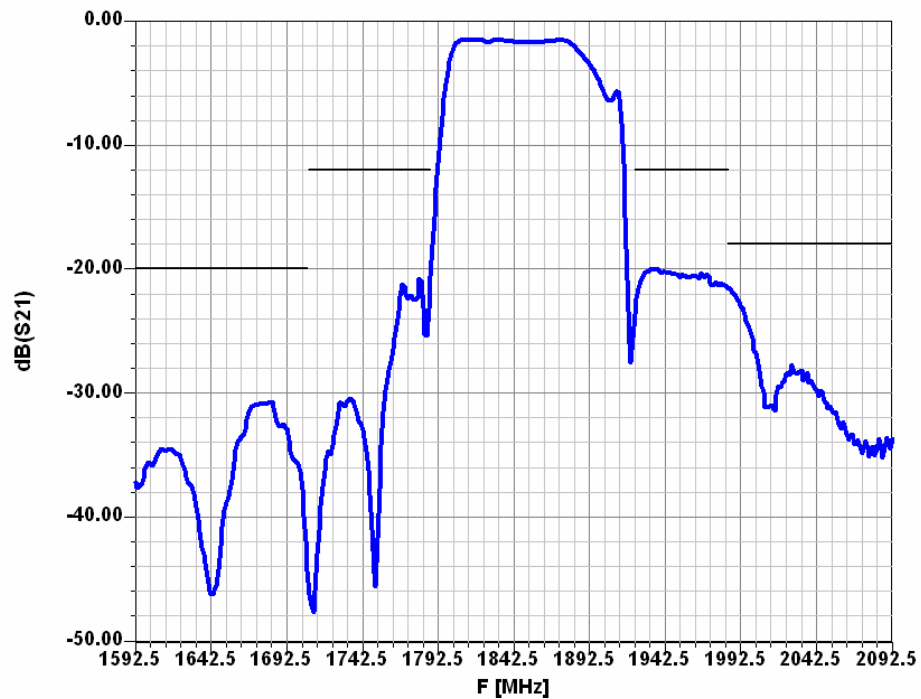
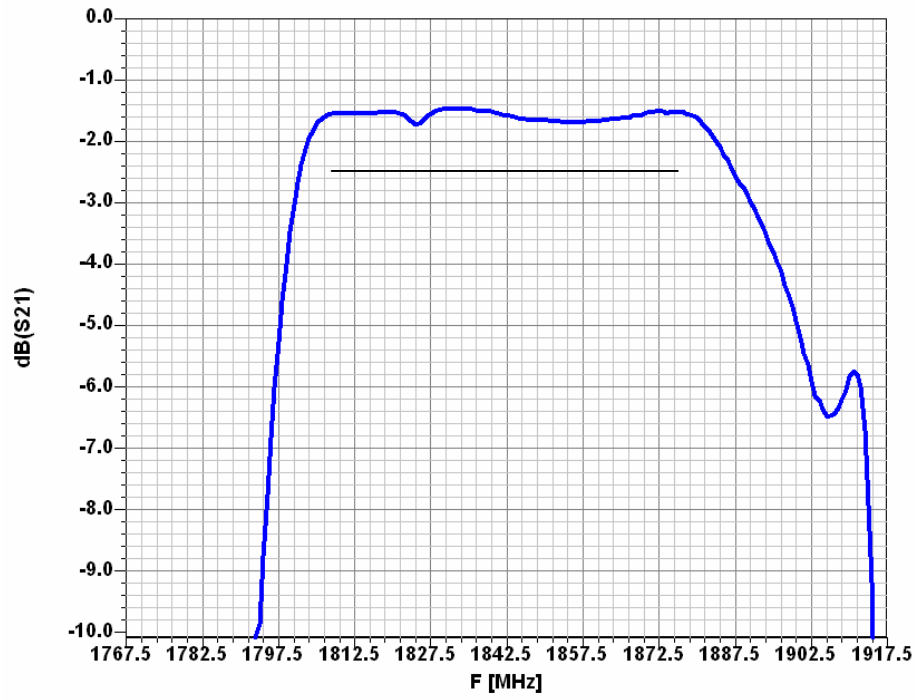

**7. Reflow Profile**

Recommended lead free reflow profile is as follows.

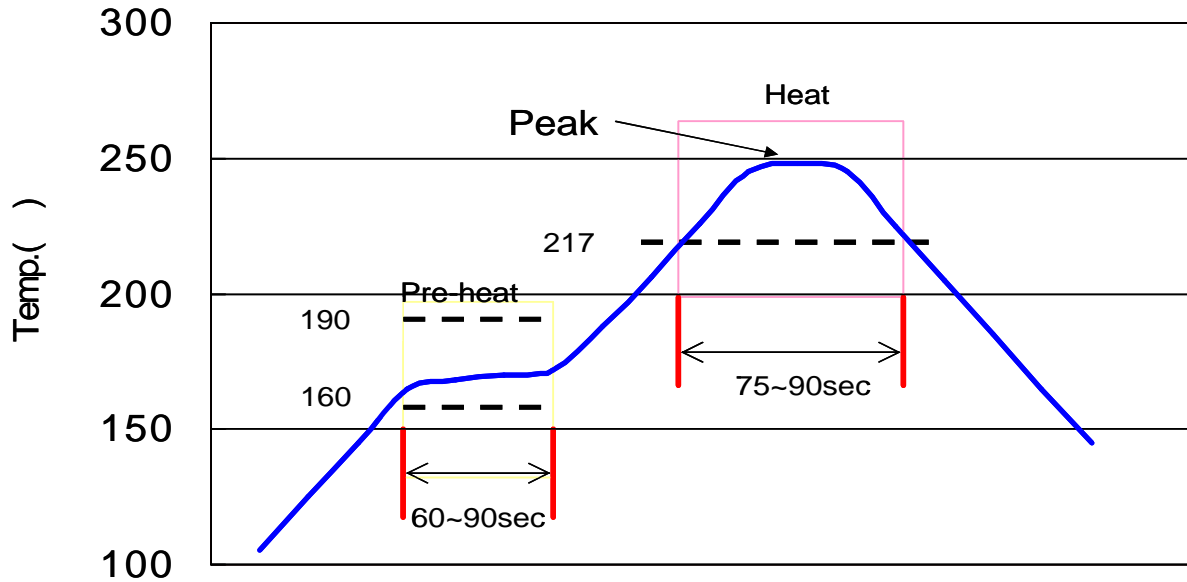

1. Ramp1 : typ2.5 /sec, max 3.0 /sec to 160
2. Pre-heat : 160~190 for 60~90sec, typ75sec
3. Ramp2 : typ2.5 /sec, max 3.0 /sec to 240 (max 260 )
4. Heat : max temp. peak 260 , typ245  
Liquidus time max 90sec, typ80 ± 5sec
5. Ramp3 : typ-2.5 /sec to room temp

**8. Standard Land Pattern**

Recommended land pattern on reflow soldering is as follows.

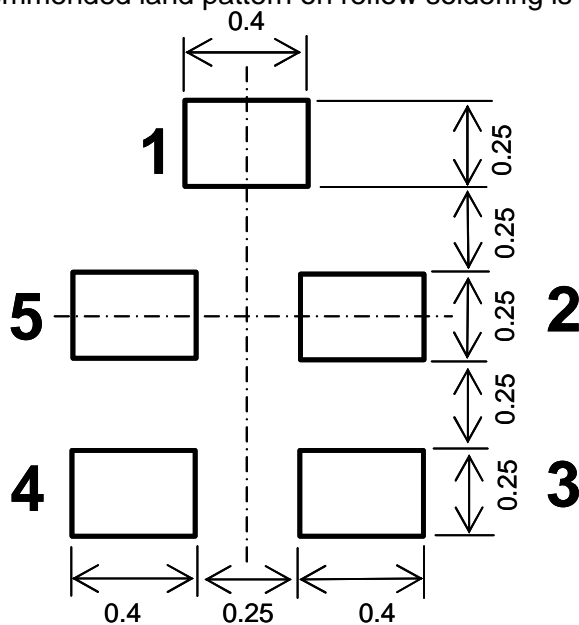

## 9. Tape and Reel

### 9-1 Dimension

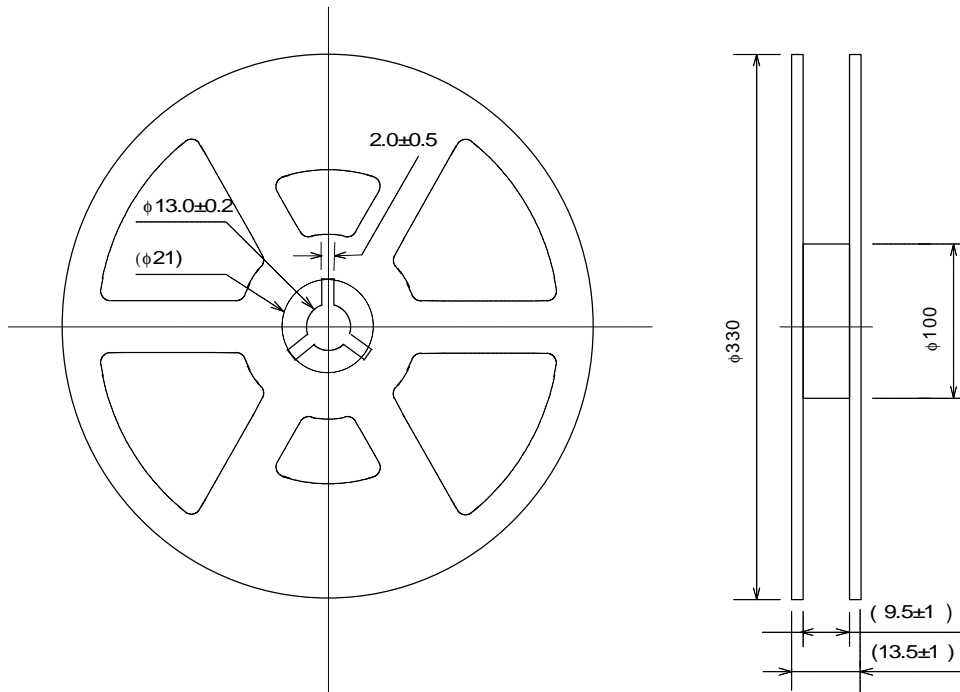

### 9-2 Pulling direction of tape

Guiding holes are on the right side of a carrier-tape when a tape is pulled off from upper side of the reel toward this side.

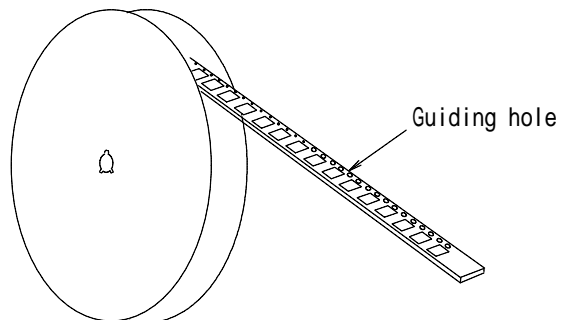

### 9-3 Cover tape

Pulling Force: 0.2N to 0.8N, Velocity: 300+/-10 mm/min

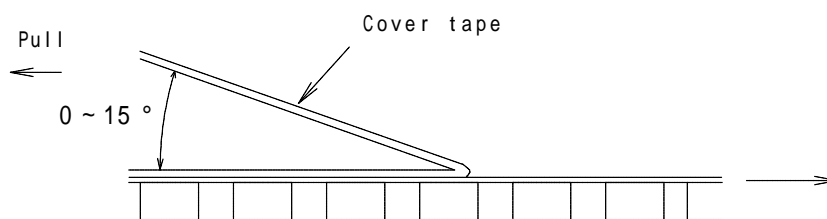

Cover tape is not to be torn while being pulled off

