

MODEL HM76 SERIES

Drum Core, Space Efficient

High Performance

Surface Mount Inductors

Inductance Range: 1 to 1,000 μ H

Rated Current: Up to 15 Amps

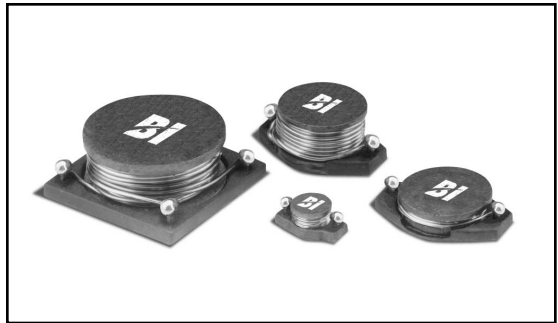

FEATURES AND BENEFITS

- High performance, high current capacities – *Meets today's circuit demands for compact size and current requirements*
- Low core loss, excellent for high frequency applications – *Designed for the latest clock speeds*
- Low profile, designed for machine placement – *Easily incorporated into volume production*
- Compatible with vapor phase and infrared reflow soldering – *No special handling necessary*
- Wide range of standard values – *Special values available*
- 1:1 coupled inductors are available in Model HM76-40xxx – *Excellent for circuit isolation* (Note 3 & 4)

APPLICATIONS

- Note book computers, PDA's
- DC/DC converters for hand held equipment
- Battery charging circuits
- EMI filters
- Inductor for general purpose
- Ideal for high current, space limited designs

ELECTRICAL / ENVIRONMENTAL

Operating Temperature Range	-40°C to +125°C
Storage Temperature Range	-40°C to +85°C
Ambient Temperature, Maximum	80°C
Insulation System	Class B, 130°C
Temperature Rise, Maximum	40°C

Specifications subject to change without notice.

SPECIFICATIONS - CASE SIZE 10 AND 20

Part Number ⁽⁵⁾	Inductance $\mu\text{H} \pm 20\%$ ⁽¹⁾	DC	Rated Current ^(2,4)	Figure
		Resistance @ 25°C ⁽³⁾ Ω Max.		
HM76-101R0 J	1.0	0.03	2.90	1
HM76-101R5 J	1.5	0.05	2.80	1
HM76-102R2 J	2.2	0.06	2.40	1
HM76-103R3 J	3.3	0.09	2.00	1
HM76-104R7 J	4.7	0.12	1.50	1
HM76-106R8 J	6.8	0.17	1.30	1
HM76-10100 J	10	0.22	1.00	1
HM76-10150 J	15	0.30	0.80	1
HM76-10220 J	22	0.43	0.70	1
HM76-10330 J	33	0.69	0.57	1
HM76-10470 J	47	0.92	0.46	1
HM76-10680 J	68	1.39	0.37	1
HM76-10101 J	100	1.98	0.28	1
HM76-10151 J	150	3.08	0.22	1
HM76-10221 J	220	4.47	0.18	1
HM76-10331 J	330	6.90	0.15	1
HM76-10471 J	470	11.55	0.12	1
HM76-20100 J or G	10	0.07	2.00	1 or 3
HM76-20150 J or G	15	0.09	1.50	1 or 3
HM76-20220 J or G	22	0.15	1.30	1 or 3
HM76-20330 J or G	33	0.21	1.10	1 or 3
HM76-20470 J or G	47	0.31	0.80	1 or 3
HM76-20680 J or G	68	0.42	0.70	1 or 3
HM76-20101 J or G	100	0.58	0.60	1 or 3
HM76-20151 J or G	150	0.89	0.50	1 or 3
HM76-20221 J or G	220	1.30	0.40	1 or 3
HM76-20331 J or G	330	2.00	0.30	1 or 3
HM76-20471 J or G	470	2.50	0.20	1 or 3
HM76-20681 J or G	680	3.50	0.10	1 or 3
HM76-20102 J or G	1,000	6.00	0.05	1 or 3

Notes: (1) Inductance measured at 100kHz, 0.1 Vrms, without DC current.

(2) Rated DC current at which inductance will be decreased by 10% from its initial value or the DC current at which $\Delta T = 40^\circ\text{C}$, whichever is smaller.

(3) Resistance measured with both windings conducted in parallel (case size 40 only).

(4) Rated current will be decreased by 50% when parts are connected as coupled inductors.

(5) Part numbers which appear in bold print are standard items and generally available from factory stock.

SPECIFICATIONS - CASE SIZE 30 AND 40

Part Number (5)	Inductance $\mu\text{H} \pm 20\%$ (1)	DC	Rated Current (2,4)	Figure
		Resistance @ 25°C (3) Ω Max.		
HM76-301R0 J or G	1.0	0.01	8.50	1 or 3
HM76-301R5 J or G	1.5	0.01	7.90	1 or 3
HM76-302R2 J or G	2.2	0.02	7.40	1 or 3
HM76-303R3 J or G	3.3	0.02	6.60	1 or 3
HM76-304R7 J or G	4.7	0.02	6.00	1 or 3
HM76-306R8 J or G	6.8	0.03	5.20	1 or 3
HM76-308R2 J or G	8.2	0.03	5.00	1 or 3
HM76-30100 J or G	10	0.04	4.60	1 or 3
HM76-30150 J or G	15	0.05	3.70	1 or 3
HM76-30220 J or G	22	0.07	3.10	1 or 3
HM76-30330 J or G	33	0.11	2.50	1 or 3
HM76-30470 J or G	47	0.16	2.00	1 or 3
HM76-30680 J or G	68	0.20	1.80	1 or 3
HM76-30820 J or G	82	0.24	1.58	1 or 3
HM76-30101 J or G	100	0.30	1.50	1 or 3
HM76-30151 J or G	150	0.44	1.20	1 or 3
HM76-30221 J or G	220	0.64	1.00	1 or 3
HM76-30331 J or G	330	1.00	0.80	1 or 3
HM76-30471 J or G	470	1.50	0.50	1 or 3
HM76-30681 J or G	680	2.20	0.40	1 or 3
HM76-30102 J or G	1,000	3.15	0.30	1 or 3
HM76-403R3 J	3.3	0.01	9.80	2
HM76-404R7 J	4.7	0.01	9.30	2
HM76-406R8 J	6.8	0.02	7.70	2
HM76-408R2 J	8.2	0.02	7.00	2
HM76-40100 J	10	0.02	6.50	2
HM76-40150 J	15	0.03	5.30	2
HM76-40220 J	22	0.04	4.40	2
HM76-40330 J	33	0.06	3.50	2
HM76-40470 J	47	0.07	3.00	2
HM76-40680 J	68	0.11	2.50	2
HM76-40820 J	82	0.12	2.20	2
HM76-40101 J	100	0.15	2.00	2
HM76-40151 J	150	0.22	1.70	2
HM76-40221 J	220	0.33	1.30	2
HM76-40331 J	330	0.45	1.10	2
HM76-40471 J	470	0.70	0.93	2
HM76-40681 J	680	1.00	0.78	2
HM76-40102 J	1,000	1.45	0.65	2

Notes: (1) Inductance measured at 100kHz, 0.1 Vrms, without DC current.

(2) Rated DC current at which inductance will be decreased by 10% from its initial value or the DC current at which $\Delta T = 40^\circ\text{C}$, whichever is smaller.

(3) Resistance measured with both windings conducted in parallel (case size 40 only).

(4) Rated current will be decreased by 50% when parts are connected as coupled inductors.

(5) Part numbers which appear in bold print are standard items and generally available from factory stock.

SPECIFICATIONS - CASE SIZE 50

Part Number ⁽⁵⁾	Inductance $\mu\text{H} \pm 20\%$ ⁽¹⁾	DC Resistance @ 25°C ⁽³⁾ Ω Max	Rated Current ^(2,4) Amps	Figure
HM76-50R78 J or G	0.78	0.003	15.0	1 or 3
HM76-501R3 J or G	1.3	0.0043	13.7	1 or 3
HM76-502R2 J or G	2.2	0.006	12.0	1 or 3
HM76-503R3 J or G	3.3	0.008	9.80	1 or 3
HM76-505R6 J or G	5.6	0.010	7.50	1 or 3
HM76-50100 J or G	10	0.023	6.00	1 or 3
HM76-50150 J or G	15	0.035	4.50	1 or 3
HM76-50220 J or G	22	0.045	4.00	1 or 3
HM76-50330 J or G	33	0.075	3.00	1 or 3
HM76-50470 J or G	47	0.096	2.60	1 or 3
HM76-50680 J or G	68	0.140	2.30	1 or 3
HM76-50101 J or G	100	0.190	1.70	1 or 3
HM76-50151 J or G	150	0.290	1.50	1 or 3
HM76-50221 J or G	220	0.410	1.20	1 or 3
HM76-50331 J or G	330	0.540	1.00	1 or 3
HM76-50471 J or G	470	0.800	0.83	1 or 3
HM76-50681 J or G	680	1.150	0.72	1 or 3
HM76-50102 J or G	1,000	1.800	0.56	1 or 3

Notes: (1) Inductance measured at 100kHz, 0.1 Vrms, without DC current.

(2) Rated DC current at which inductance will be decreased by 10% from its initial value or the DC current at which $\Delta T = 40^\circ\text{C}$, whichever is smaller.

(3) Resistance measured with both windings conducted in parallel (case size 40 only).

(4) Rated current will be decreased by 50% when parts are connected as coupled inductors.

(5) Part numbers which appear in bold print are standard items and generally available from factory stock.

SCHEMATICS

Figure 1 & 3

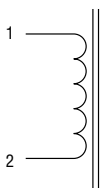
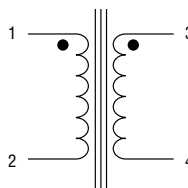

Figure 2



OUTLINE DIMENSIONS (INCH/mm)

Termination Type 'J'

Figure 1
(Case Sizes: 10, 20, 30 & 50)

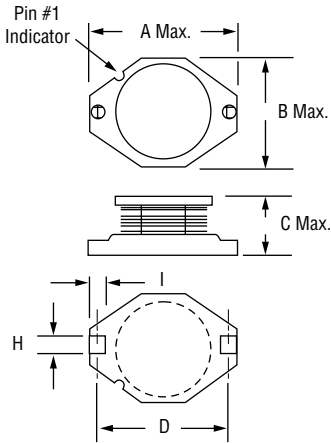
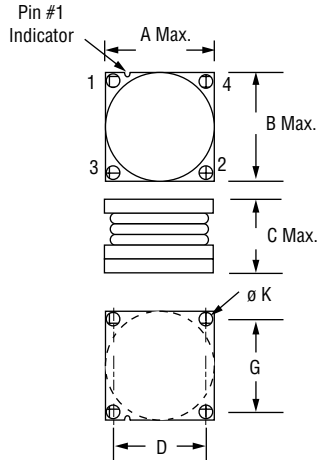
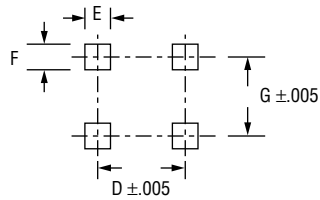
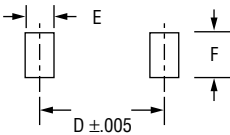

Figure 2
(Case Size: 40)



Recommended Solder Pad Layout



Case Size	Fig.	A	B	C	D	E	F	G	H	I	K
10	1	.280	.188	.127	.218	.059	.10	-	.067	.051	-
		7.30	4.78	3.23	5.54	1.50	2.54	-	1.70	1.30	-
20	1	.530	.370	.137	.404	.120	.135	-	.102	.107	-
		13.46	9.40	3.50	10.26	3.05	3.43	-	2.59	2.72	-
30	1	.530	.370	.232	.404	.120	.135	-	.102	.107	-
		13.46	9.40	5.90	10.26	3.05	3.43	-	2.59	2.72	-
40	2	.634	.622	.284	.520	.157	.157	.466	-	-	.100
		16.10	15.80	7.21	13.21	4.00	4.00	11.84	-	-	2.54
50	1	.746	.60	.284	.595	.145	.135	-	.102	.107	-
		18.95	15.24	7.21	15.11	3.68	3.43	-	2.59	2.72	-

OUTLINE DIMENSIONS (INCH/mm)

Termination Type 'G'

Figure 3
(Case Sizes: 20, 30 & 50)

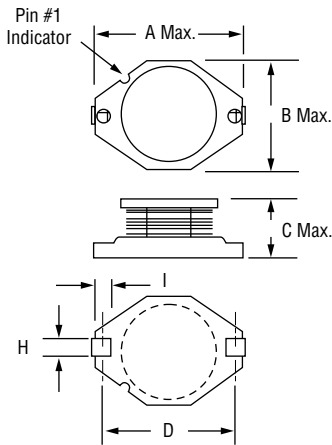

Recommended Solder Pad Layout

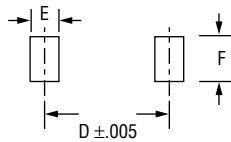

Case Size	Fig.	A	B	C	D	E	F	H	I
20	3	.595	.370	.137	.492	.120	.135	.102	.107
		15.11	9.40	3.50	12.50	3.05	3.43	2.59	2.72
30	3	.595	.370	.232	.492	.120	.135	.102	.107
		15.11	9.40	5.90	12.50	3.05	3.43	2.59	2.72
50	3	.790	.600	.284	.700	.145	.135	.102	.107
		20.07	15.24	7.21	17.78	3.68	2.43	2.59	2.72

Note: Case size 10 and 40 not available in this model.

TAPE AND REEL (Inch/mm)

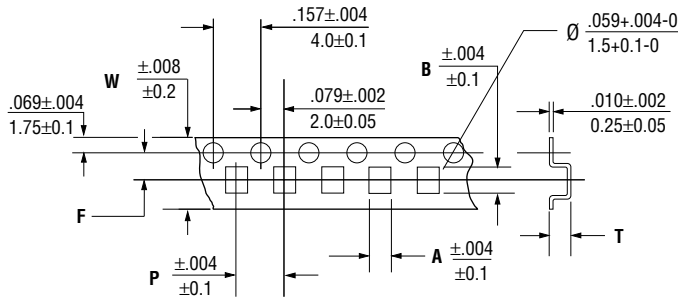

Tape Material: Polystyrene

Case Size	A Dim.	B Dim.	F Dim.	W Dim.	P Dim.	T Dim.
10	.185	.291	.217	.473	.315	.138
	4.70	7.40	5.5	12.0	8.00	3.50
20	.390	.543	.453	.945	.473	.138
	9.90	13.8	11.5	24.0	12.0	3.50
30	.390	.543	.453	.945	.630	.236
	9.90	13.8	11.5	24.0	16.0	6.00
40	.630	.630	.453	.945	.945	.307
	16.0	16.0	11.5	24.0	24.0	7.80
50	.610	.748	.559	1.26	.945	.315
	15.5	19.0	14.2	32.0	24.0	8.00

PACKAGING

Standard: Embossed Tape & Reel

All units oriented with lead #1 to the same side of sprocket hole.

Reel Capacity	Case Size 10	=	500 Units
	Case Size 20	=	1,000 Units
	Case Size 30	=	350 Units
	Case Size 40	=	200 Units
	Case Size 50	=	200 Units
Diameter	Case Size 10	=	7" (177.8mm)
	All Other Case Sizes	=	13" (330.2mm)

ORDERING INFORMATION

