

MODEL 66

3/8" Square

Multiturn

Cermet Trimming

Potentiometer

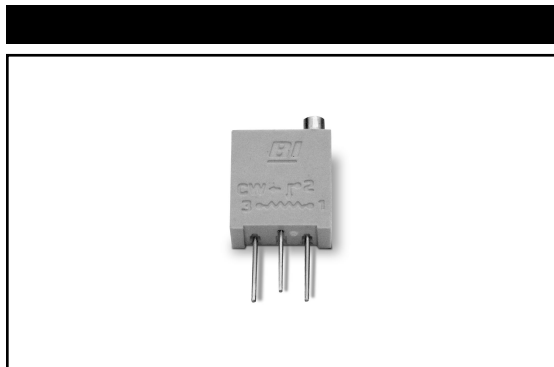

1

ELECTRICAL

Standard Resistance Range, Ohms	10 to 2Meg
Standard Resistance Tolerance	±10% (<100 Ohms = ±20%)
Input Voltage, Maximum	200 Vdc or rms not to exceed power rating
Slider Current, Maximum	100mA or within rated power, whichever is less
Power Rating, Watts	0.5 at 70°C derating to 0 at 125°C
End Resistance, Maximum	2 Ohms
Actual Electrical Travel, Turns, Nominal	20
Dielectric Strength	1,000 Vrms
Insulation Resistance, Minimum	1,000 Megohms
Resolution	Essentially infinite
Contact Resistance Variation, Maximum	1% or 1 Ohm, whichever is greater

ENVIRONMENTAL

Seal	85°C Fluorinert® (No Leaks)
Temperature Coefficient, Maximum	±100ppm/°C
Operating Temperature Range	-65°C to +150°C
Thermal Shock	5 cycles, -65°C to +150°C (1% ΔRT, 1% ΔVR)
Moisture Resistance	Ten 24 hour cycles (1% ΔRT, IR 1,000 Megohms min.)
Shock, 6ms Sawtooth	100G's (1% ΔRT, 1% ΔVR)
Vibration	20G's, 10 to 2,000 Hz (1% ΔRT, 1% ΔVR)
High Temperature Exposure	250 hours at 125°C (2% ΔRT, 2% ΔVR)
Rotational Life	200 cycles (3% ΔRT)
Load Life at 0.5 Watts	1,000 hours at 70°C (2% ΔRT)
Resistance to Solder Heat	260°C for 10 sec. (1% ΔRT)

MECHANICAL

Mechanical Stops	Clutch Action, both ends
Torque, Starting Maximum	5 oz.-in. (0.035 N-m)
Weight, Nominal	.04 oz. (1.13 grams)

Fluorinert® is a registered trademark of 3M Company.
 Specifications subject to change without notice.

TOP ADJUSTMENT (Inch/mm)

Model 66W

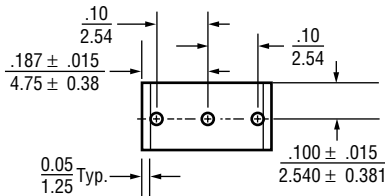
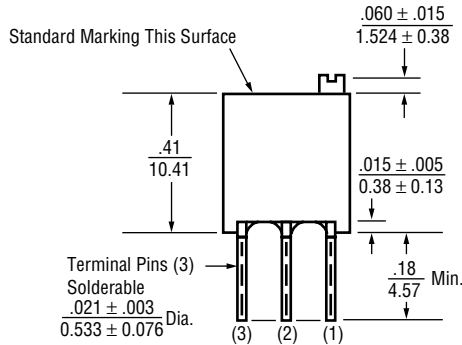
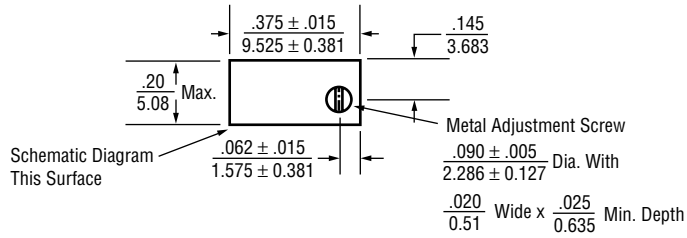

SIDE ADJUSTMENT (Inch/mm)

Model 66P

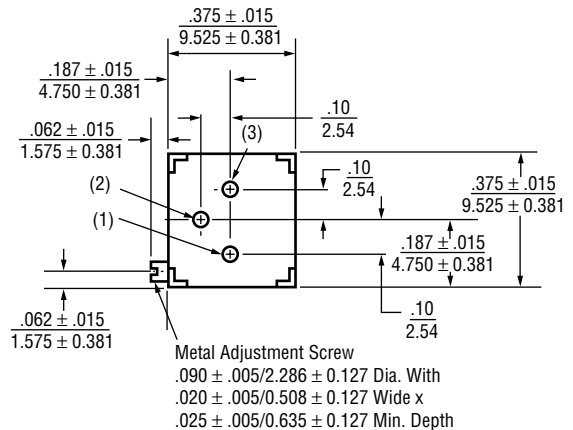
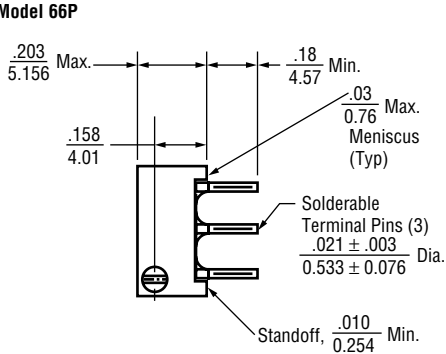

SIDE ADJUSTMENT (Inch/mm)

Model 66X

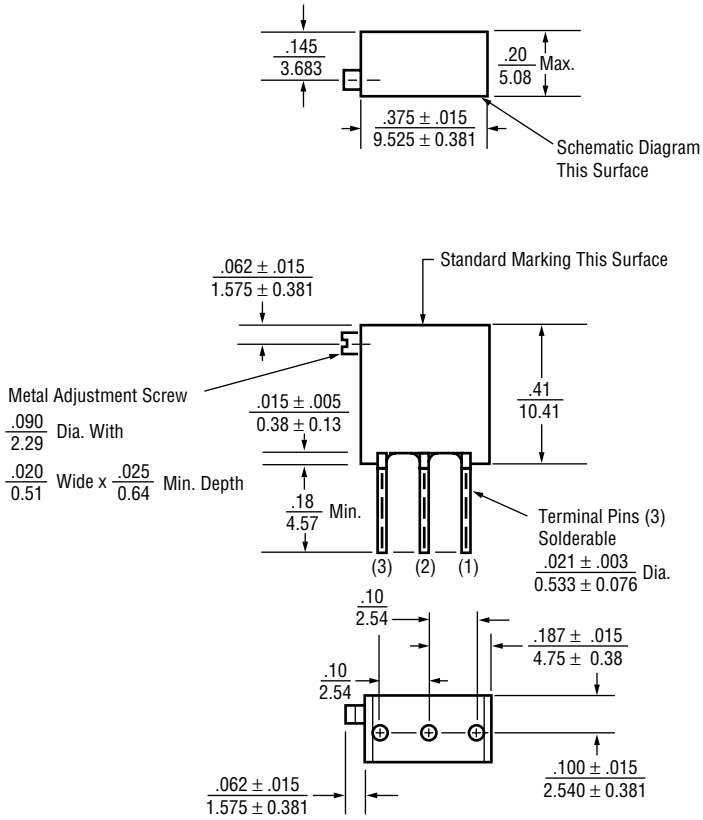

STANDARD RESISTANCE VALUES, OHMS

10	200	5K	50K	500
20	500	10K	100K	1Meg
50	1K	20K	200K	2Meg
100	2K	25K	250K	

PACKAGING

Standard: Boxes
 Capacity = 100 Units (66W)
 = 50 Units (All other styles)

Option: Tubes
 All units oriented with #1 pin to same side.

	Pin Style		P	W	X
Magazine	Width	=	0.57"	0.28"	0.28"
	Height	=	0.66"	0.93"	0.93"
	Length	=	20.9"	20.6"	24.4"
	Capacity	=	50 Units	50 Units	50 Units

Option: Tape & Reel, Ammo Pack (Available only for 66X and 66W)
 All units oriented with #1 pin to the right of the direction of feed.

	Seat Plane to Centerline of Sprocket Hole	=	.71" (18 mm)
Tape	Width	=	18 mm
	Sprocket	=	Single Hole .50" spacing
	Capacity	=	1,000 Units
Reel	Diameter	=	14" (363 mm)
Ammo Box	Tape Fold	=	12" (305 mm)
		=	1.8" x 13" x 10" (46mm x 330mm x 254mm)